

Rotor Cap Remover

User instructions

2.5mm RS-301-2180

3.2mm RS-301-3180

4.0mm RS-301-4180

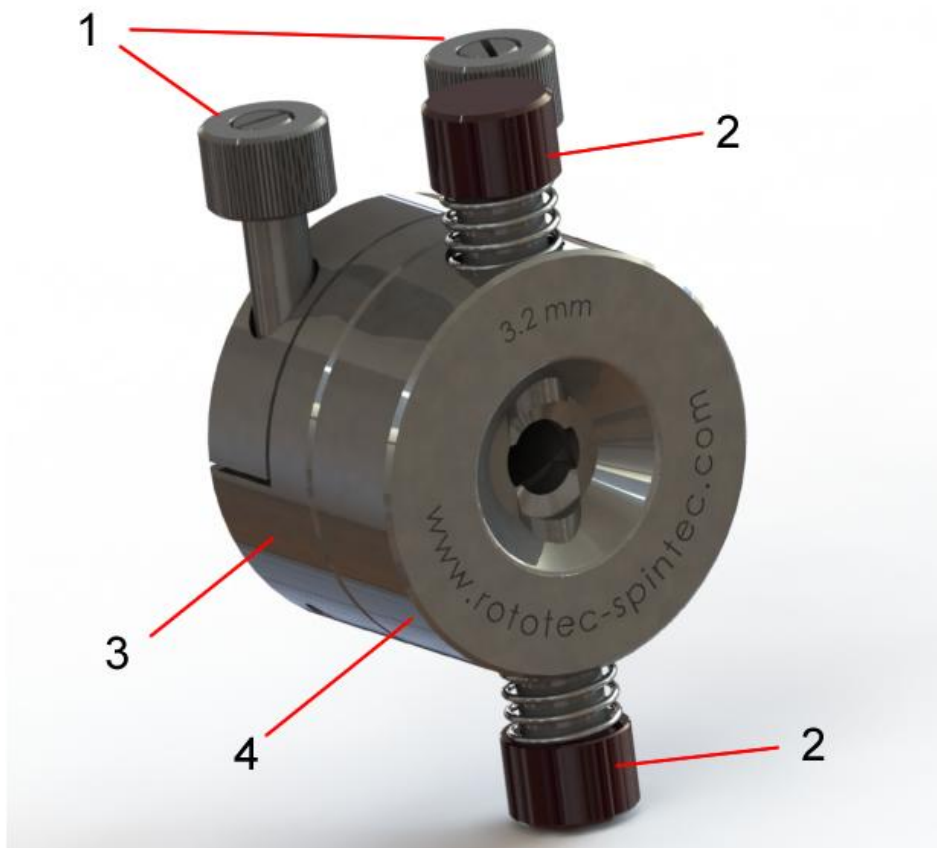

Step 1.

The Cap Remover consists of 2 parts, please unscrew in a counter clock wise manner the cap remover finger section (4) from the rotor clamp section (3).

Step 2.

Now insert the rotor including the turbine blade cap and bottom plug into the finger section of the cap remover. In this example we are going to remove the turbine blade or drive cap from the rotor. Should it be required to remove the base plug simply invert the rotor. The procedure stays the same.



Step 3.

Whilst gripping the rotor sleeve with one hand, lightly depress the fingers (2) until contact is made with the ceramic rotor sleeve.



Step 4.

Push the rotor into the cap remover in the direction of the arrow whilst maintaining a very slight positive pressure on the fingers up against the rotor sleeve. As soon as the slight indentation between the rotor sleeve and end cap is reached you will feel this in the fingers as they will go into this slight recess.



Step 5.

When you are 100% certain the fingers are securely in this gap between the rotor sleeve and end cap, increment the pressure on the two fingers substantially until an audible 'click' is heard.

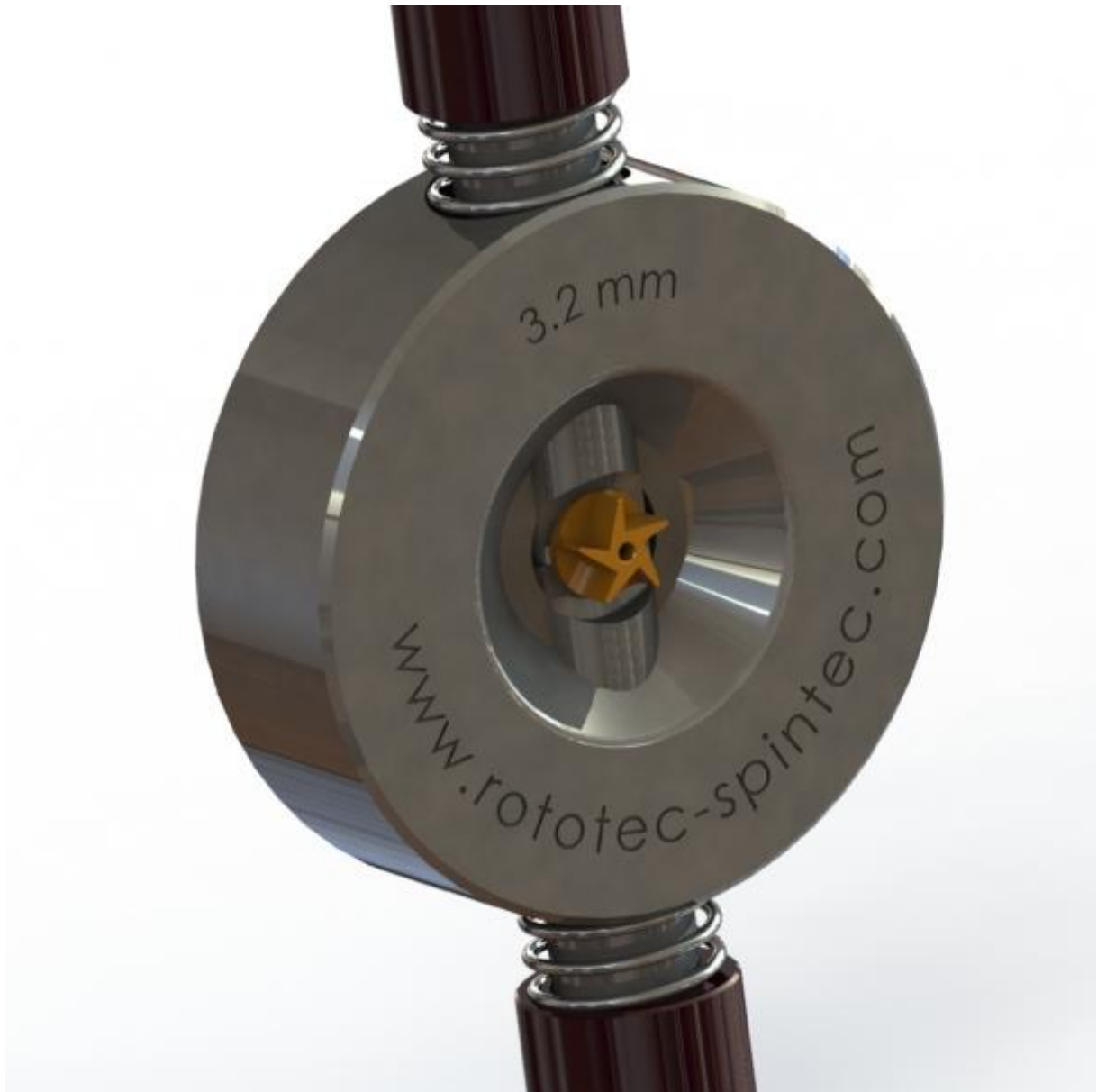

Step 6.

Release the force on the fingers (2) and remove the rotor.



Step 7.

It should now be absolutely clear that there is now a substantial gap between the rotor ceramic sleeve and the polymer based turbine blade end cap.

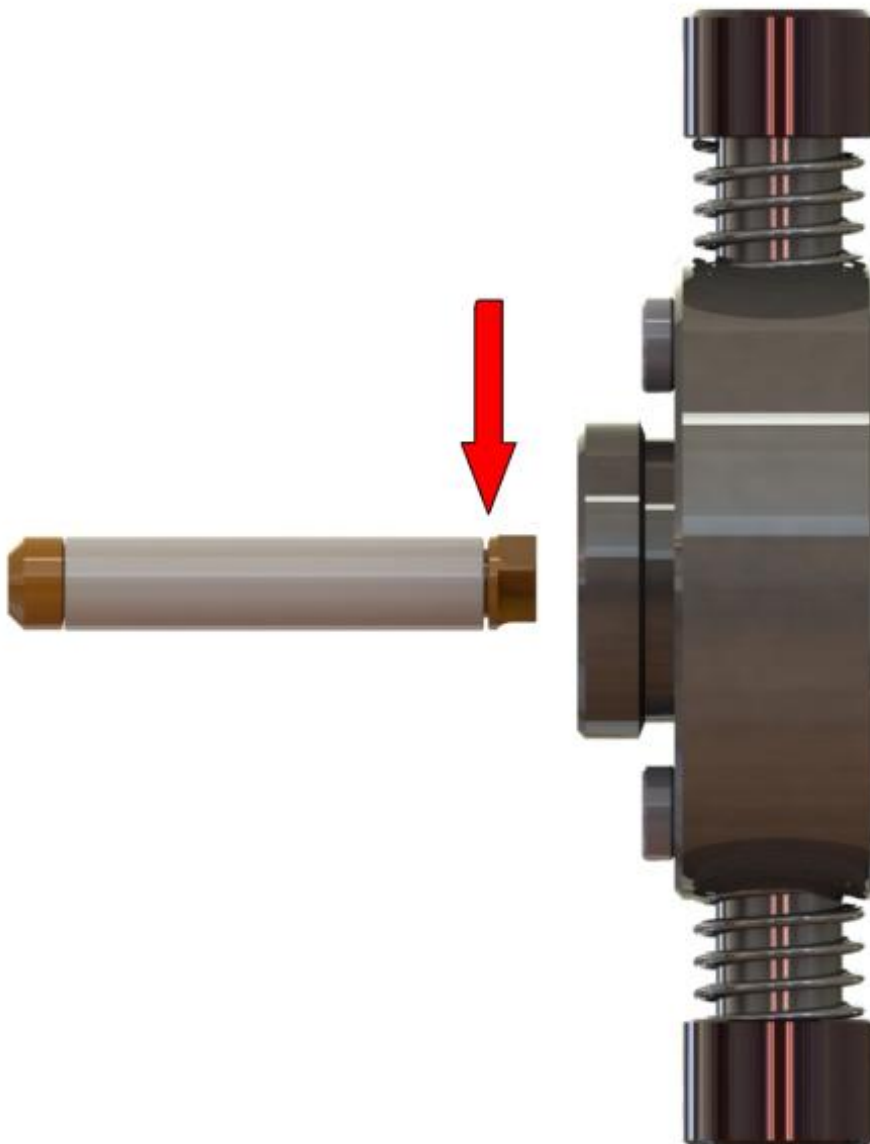

Step 8.

Insert the rotor into the rotor clamp (3). Tighten the thumb screws (1) in a symmetrical fashion just enough to ensure all axial play is removed but the rotor can still easily move a little forward and backwards.



Step 9.

Screw the two cap remover sections (3 & 4) together until finger tight.



Step 10.

Now you are essentially going to repeat step number 4 and position this increased gap between the rotor ceramic sleeve and the turbine blade end cap:

Press the rotor in the direction of the arrow whilst maintain a slight positive pressure on the two fingers in (2) until they clearly engage the gap achieved in the previous sections.



Step 11.

Whilst holding the two fingers (2) firmly in the gap with one hand, tighten the two rotor clamp fingers (1) in a symmetrical fashion with your other hand until the rotor ceramic sleeve is firmly held.



Step 12.

Now rotate the rotor clamp (3) slowly away from the cap remover finger section (4), maintaining the pressure on the two fingers (2) in the gap between the rotor sleeve and end cap or bottom plug. If the bond between the ceramic rotor sleeve and the polymer based end cap is substantial, the cap or base plug will rotate in sympathy with the rotor until such time as this bond is too weak or the end cap or plug releases from the rotor.



Step 13.

After you have completely unscrewed the rotor clamp section away from the rotor finger section you should see the rotor ceramic sleeve securely held in the rotor clamp section. Should this not be the case, repeat step 11 and make the tension on the finger tightened screws securing the rotor sleeve in the rotor sleeve clamp slightly tighter, if need be using a small flat blade screwdriver. Most of the time simply making the gap across the rotor sleeve more symmetrical is sufficient grip to unscrew the one rotor component from the other.



Experienced users can in time skip steps 1-3 and start at step 4. This is only recommended if a degree of ‘feeling’ is already achieved. At no point should the sharp fingers be pressed into the delicate and sensitive rotor ceramic sleeve or turbine blade end cap with considerable force, it should always be ‘felt’ into position.